

BSWS Jaw quick-change systems

BSWS, BSWS-M, BSWS-R

Hand in hand for tomorrow



Change of fingers with SCHUNK

Productive, flexible and cost-efficient

The BSWS series combines all these key features. With our jaw quick-change system, you can change top jaws quickly and easily, no matter if it is done with an Allen key, at the push of a button, or automated using a robot.

The finger change reduces set-up time to a minimum and enhances productivity. In applications with a high number of variants and small batch sizes, the BSWS provides the necessary flexibility for your system. The series offers a wide range of variants and sizes to ensure that you can find the right component for any application.

Your advantages

- + **Maximum flexibility:** Thanks to the BSWS product family, one single gripper can be used universally in various applications
- + **Time saving when converting applications** based on finger change, various workpieces can be handled
- + **PGN-plus-P Fingerprint** enables universal use and retrofitting for a variety of gripper series

BSWS Manually operated tool

The BSWS allows the gripper fingers to be changed manually using an Allen key. It enables quick and easy locking and unlocking, while the form-fit locking mechanism ensures that the gripper fingers can be replaced quickly. This is the ideal choice for applications where tool actuation is not a restriction and a quick finger change is required.

BSWS-M Manual tool-free operation

The BSWS-M is characterized by its tool-free, manual operation. Simply press the release button to mechanically unlock the top jaw and immediately remove it from the gripper. This particularly pays off in case of frequent set-up processes and ensures high flexibility and efficiency in adapting your grippers to different requirements.

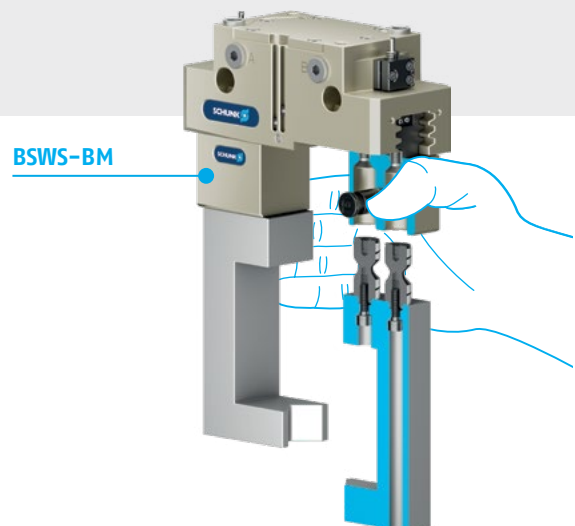
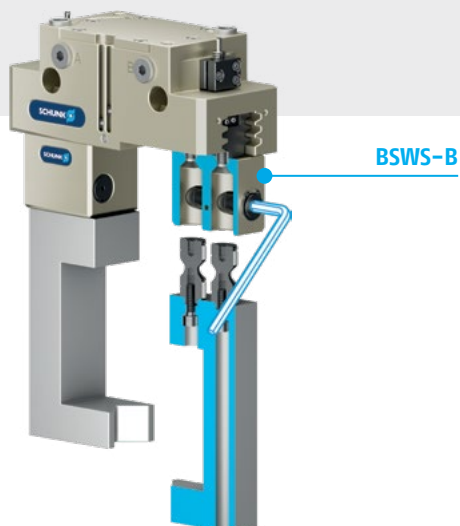

The BSWS product family

for any case of application the right version

PGN-plus-P Fingerprint

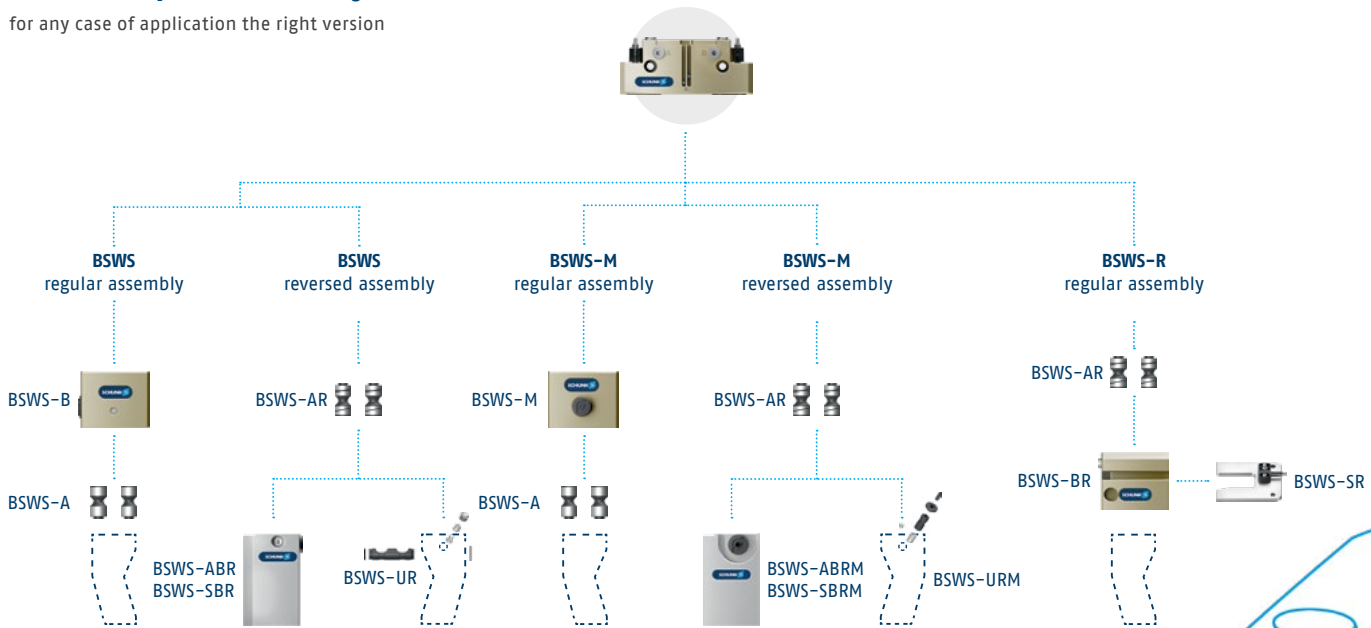

BSWS-R automatic

The BSWS-R allows fully automatic exchange of gripper fingers, without manual intervention. The change process is carried out exclusively by the movement of the robot. When the base is retracted into the storage station, the locking bolt is actuated and unlocks the mechanism. As a result, a robot or an axis gantry can easily move upwards out of the jaw quick-change system while the base remains in the deposit station. Each gripper finger can be exchanged in just a few seconds. As a result, the system offers maximum efficiency and precision while enabling unmanned availability of the systems.

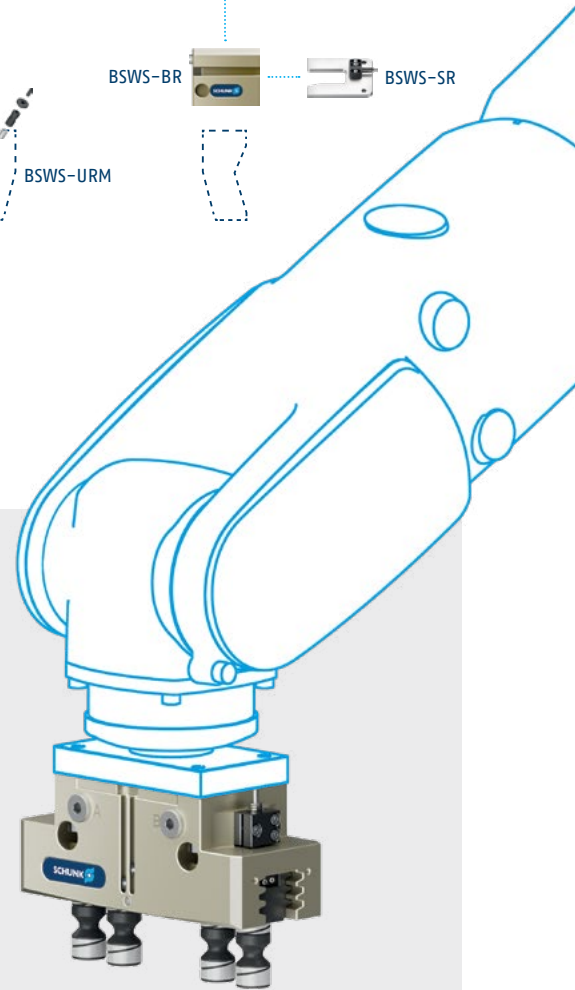

Even more advantages

- + Suitable for operation on cobots**
The storage station is elastically mounted and therefore prevents overloading of the robot
- + Simple finger design**
The need to bolting through the gripper fingers is no longer required, only a thread needs to be inserted into the finger
- + Process safety** due to presence control of the gripper fingers in the storage station via inductive proximity switch
- + No mix-up of the gripper jaws** due to finger coding via RFID data carrier





SCHUNK SE & Co. KG
Spanntechnik
Greiftechnik
Automatisierungstechnik
Bahnhofstr. 106 – 134
D-74348 Lauffen/Neckar
Tel. +49-7133-103-2599
schunk.com

Follow us



We print sustainably

